

UD3300

2004 MODEL YEAR



TRUCKS

Distributed by

Nissan Diesel America, Inc.

WHEELBASES

	E	H	K	M	R
GVWR (lb.)	32,900	32,900	32,900	32,900	32,900
Chassis Weight (lb.)	10,250	10,360	10,470	10,580	10,790
Front (lb.)	6,150	6,215	6,280	6,325	6,450
Rear (lb.)	4,100	4,145	4,145	4,255	4,340
Gross Payload (lb.)*	22,650	22,540	22,430	22,320	22,110
Wheelbase (in.) ** WB	156.3	177.2	192.9	208.7	238.2
Cab-to-Rear Axle (in.) CA	123.1	143.9	159.7	175.4	204.9
Rear Overhang (in.) RO	67.1	70.1	74.2	85.8	107.5
Overall Length (in.) OL	276.6	300.4	320.3	347.6	398.8
Typical Body Lengths (ft.)*** 14/16	16/18	18/20	20/22	24/26	
Turning Radius (ft.)	22.2	25.2	27.2	29.2	32.8

*Gross payload capacity equals GVWR minus chassis weight. Installation of specialized equipment or bodies may require frame reinforcement. **Wheelbase selection should be based on specific weight distribution. ***Typical body lengths assume water level load (no specific consideration for driver, passengers, or fuel) to maximize GVWR. Addition of ancillary equipment such as lift gates and refrigeration units not considered in calculations.

ENGINE

	Nissan Diesel FE6TA - 24 Valve Turbo/Intercooled Diesel In-line 6 cylinder, Direct-injection
Horsepower	225 hp @ 2,600 rpm
Torque w/Manual Trans.	492 lb. ft. @ 1,600 rpm
Displacement	423 in. ³ (6.9 L)
Cylinder Liner	Dry, replaceable
Air Compressor	15 CFM @ 2,500 engine rpm (1,250 compressor rpm)
Fuel Injection	BOSCH/ZEXEL, MD-TICS injection pump with all-speed governor
Air Cleaner	13 in., dry type
Cold Starting Aid	Automatic electric intake air heater
Fan	Viscous type drive

FRONT AXLE

Rated Axle Capacity	11,900 lb.
Axle Type	"I" Beam
Suspension	Semi-elliptic leaf springs
Shock Absorbers	Telescopic type



*UD3300 shown here with dealer installed optional equipment.

TRANSMISSION

STD
Nissan Diesel, MLS62B
Manual, 6 forward speeds & 1 reverse synchromesh on 2nd through 6th gears

Ratios

1st	-----6.72		
2nd	-----4.03		
3rd	-----2.30		
4th	-----1.44		
5th	-----1.00		
6th	-----0.74		
Rev.	-----6.12		
R/A Ratio	-----6.50 ^{STD}	-----6.17	-----6.83
rpm @ 65 mph	-----2,610	-----2,480	-----2,750

CLUTCH

Hydraulic clutch with air assist
13.8 in. cerametallic friction material
Standard clutch wear indicator

STEERING

Integral power steering, gear driven pump
Steering Column Tilt & telescopic type

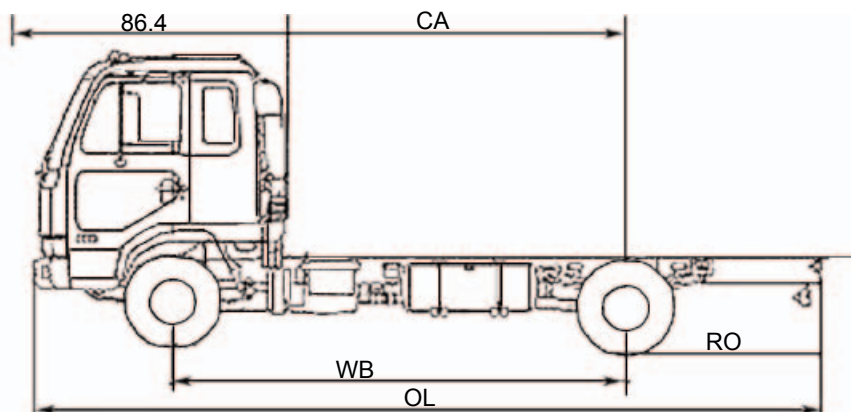
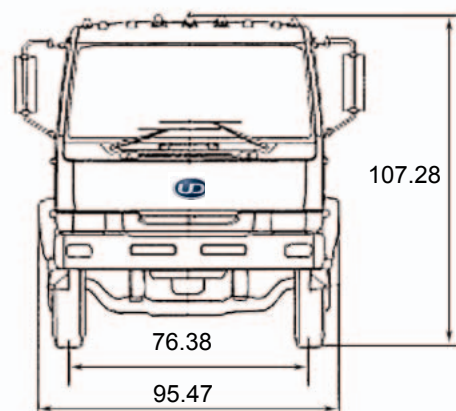

UD3300



TRUCKS

Distributed by
Nissan Diesel America, Inc.

REAR AXLE

Rated Axle Capacity	21,000 lb.
Axle Type	Full-floating banjo housing
Suspension	Semi-elliptic leaf springs with auxiliary springs

WHEELS & TIRES

Tires	Front: Single, highway tread Rear: Dual, traction type 11R22.5 - 14PR (tubeless radial)
Wheels	Steel disc type, 8 hole, 7.50 x 22.5 in., offset 6.38 in.

BRAKE SYSTEM

Service Brakes	Anti-lock Braking System "S" cam air brake system with automatic slack adjusters
Front	Drum diameter x lining width x lining thickness: 16.14 x 5.91 x 0.63 in.
Rear	Drum diameter x lining width x lining thickness: 16.14 x 8.66 x 0.63 in.
Air Tanks	Supply: 1,819 in. ³ Front service: 732 in. ³ Rear service: 1,806 in. ³ Total: 3,637 in. ³
Air Dryer	Standard
Parking Brake	Pneumatically controlled spring brakes, operated by push/pull button, acting on rear wheels

EXHAUST BRAKE

Electrically controlled, pneumatically activated butterfly valve in exhaust pipe

CHASSIS FRAME

Ladder type, channel section side rails

Dimensions (in.)*	9.84 x 3.15 x 0.31 Assembled width 33.9
Section Modulus (in. ³)**	35.7 (with reinforcement) 26.6 (W/B -E only, without reinforcement)
Yield Strength (psi)	42,600
RBM (in.-lb.) chassis	1,521,000
per-rail	760,500

*Height x Flange Width x Thickness

**Measured at back-of-cab

FUEL TANK

Round fuel tank, mounted to left side
Capacity - 50 gallons

CAB

Forward control, steel welded construction, tilting cab. Cab suspension with hydraulic shock absorbers

Cab Glass	Windshield, tinted laminated, 2,314 in. ²
Door Locks	Driver & passenger, electric control
Door Vent Window	Driver, ventilating type
Driver's Seat	Height & seat back angle adjustable Cloth cover, high back type
Passenger Seat	Seat back angle adjustable Cloth cover, high back type
Seat Belts	Driver & passenger, 3-point ELR type
Rearview Mirrors	West coast type, 6.0 x 15.1 in.
Steering Column	Tilt & telescopic type
Sun Visors	Driver & passenger
Windows	Driver & passenger, electric control
Windshield Wipers	Dual, electric-driven, intermittent & 2 speed

ELECTRICAL EQUIPMENT

Halogen headlights, 2 lamps
Back-up lights
Cigar lighter
Clearance, identification & position lights
Day-time running lights
Interior and map light
License light
Side turn signal lights
Stop/tail lights
Turn signal/hazard lights

INSTRUMENTS

Meters & Gauges

Air pressure gauges
Coolant temperature gauge
Fuel gauge
Speedometer, odometer & trip meter
Tachometer

Warning & Indicator Lights & Buzzers

ABS warning light
Air filter service light
Air heater indicator light
Alternator low charge warning light
Cab lock warning light & buzzer
Engine control system warning light
Exhaust brake indicator light
Hazard warning flasher
High beam indicator light
Low air pressure warning light & buzzer
Low coolant level & overheating warning light & buzzer
Low oil pressure warning light
Parking brake indicator light
Turn signal indicator lights
Warning lights with burnt-out bulb check function

OTHER OPTIONS

Air conditioner
AM/FM stereo radio with CD
Block heater
Center console/ third seat
Driver's suspension seat

All illustrations, specifications and descriptions in this specification are based on the latest product information available at the time of this publication. The right is reserved to make changes in price, materials, equipment, design, specifications, diagrams and models, and to discontinue models of equipment at any time, without notice and without incurring any obligation whatsoever. For more information on additional options and accessories, contact NISSAN DIESEL AMERICA, INC.

Manufacturer:
NISSAN DIESEL MOTOR CO., LTD.
Tokyo, Japan

Distributor:
NISSAN DIESEL AMERICA, INC.
P.O. Box 152034
Irving, Texas 75015-2034
www.nissandiesel.com