

# UD1200

2004 MODEL YEAR



Distributed by

Nissan Diesel America, Inc.

## WHEELBASES

	A	C	E
GVWR (lb.)	12,000	12,000	12,000
Chassis Weight (lb.)	5,225	5,335	5,445
Front (lb.)	3,585	3,705	3,780
Rear (lb.)	1,640	1,630	1,665
Gross Payload (lb.)*	6,775	6,665	6,555
Wheelbase (in.)** WB	108.9	131.9	149.4
Cab-to-Rear Axle (in.) CA	83.4	106.4	123.9
Rear Overhang (in.) RO	49.6	49.6	49.6
Overall Length (in.) OL	203.2	226.2	243.7
Typical Body Lengths (ft.)***	10/12	14/16	16/18
Turning Radius (ft.)	17.4	20.7	23.0

\*Gross payload capacity equals GVWR minus chassis weight. Installation of specialized equipment or bodies may require frame reinforcement. \*\*Wheelbase selection should be based on specific weight distribution. \*\*\*Typical body lengths assume water level load (no specific consideration for driver, passengers, or fuel) to maximize GVWR. Addition of ancillary equipment such as lift gates and refrigeration units not considered in calculations.

## ENGINE

	Nissan Diesel FD46TA Turbo/Intercooled Diesel In-line 4 cylinder, Direct-injection
Horsepower w/ Manual Trans.	145 hp @ 2,800 rpm
Horsepower w/ Auto. Trans.	175 hp @ 2,800 rpm
Torque w/ Manual Trans.	275 lb. ft. @ 1,800 rpm
Torque w/ Auto. Trans.	334 lb. ft. @ 1,800 rpm
Displacement	282 in. <sup>3</sup> (4.6 L)
Cylinder Liner	Dry, replaceable
Fuel Injection	BOSCH/ZEXEL, MD-TICS injection pump with all-speed governor
Air Cleaner	11.0 in., dry type
Cold Starting Aid	Automatic electric intake air heater
Fan	Viscous type drive

## FRONT AXLE

GAWR	4,670 lb.
Rated Axle Capacity	6,170 lb.
Axle Type	"I" Beam
Suspension	Semi-elliptic leaf springs
Shock Absorbers	Double acting, telescopic type



\*UD1200 shown here with dealer installed optional equipment.

## TRANSMISSION

	STD Nissan Diesel, MES50C Manual, 5 forward speeds & 1 reverse synchronesh in all gears	OPTION Aisin A45043L Automatic Full electronic control 4 speed overdrive with lockup & park lock
<b>Ratios</b>		
1st	5.10	3.02
2nd	3.01	1.55
3rd	1.64	1.00
4th	1.00	0.70
5th	0.75	—
Rev.	4.86	2.68
R/A Ratio	4.88	5.29 <sup>STD</sup>
rpm @ 65 mph	2,700	2,920 <sup>STD</sup>
		2,880

## CLUTCH

11.8 in. non-asbestos friction material  
Standard clutch wear indicator

## STEERING

Integral power steering  
Steering Column Tilt & telescopic type

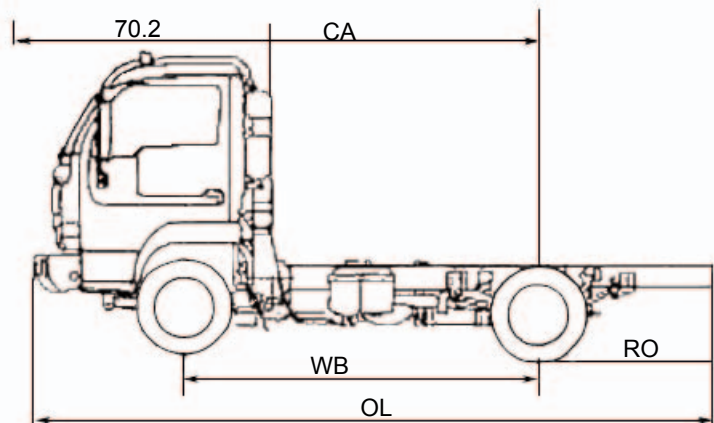
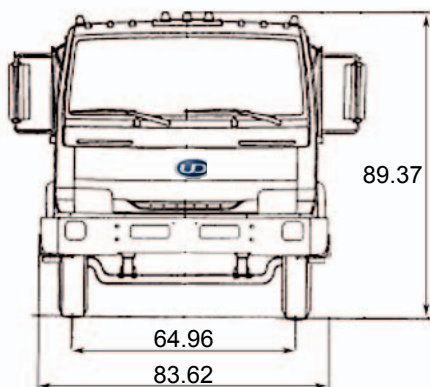

# UD1200



# TRUCKS

Distributed by  
**Nissan Diesel America, Inc.**

## REAR AXLE

GAWR	8,600 lb.
Rated Axle Capacity	11,500 lb.
Axle Type	Full-floating banjo housing
Suspension	Semi-elliptic leaf springs with auxiliary springs
Shock Absorbers	Double acting, telescopic type

## WHEELS & TIRES

Tires	Front: Single, highway tread Rear: Dual, traction type 215/85R16 - 8PR (tubeless radial)
Wheels	Steel disc type, 5 hole, 6 x 16 in., offset 5.0 in.

## BRAKE SYSTEM

Service Brakes	Anti-lock Braking System Dual line, hydraulic brake system with vacuum assist
Front	Ventilated disc brakes
Rear	Internal expanding, dual two leading shoe, self-adjusting drum brakes
Parking Brake	Hand brake lever activating drum at rear of transmission

## EXHAUST BRAKE

Electrically controlled, vacuum activated  
butterfly valve in exhaust pipe

## CHASSIS FRAME

Ladder type, channel section side rails

Dimensions (in.) *	7.09 x 2.36 x 0.18
Assembled Width (in.)	29.5
Section Modulus (in. <sup>3</sup> ) **	6.29 (per rail)
Yield Strength (psi)	44,000
RBM (in.-lb.) chassis	554,000
per-rail	277,000
Rear Inner Reinforcement	STD on E Wheelbase

\*Height x Flange Width x Thickness

\*\*Measured at back-of-cab

## FUEL TANK

Round fuel tank, mounted to right side  
Capacity - 33 gallons

## CAB

	Forward control, steel welded construction, tilting cab with cab suspension
Assist Handles	Two, driver & passenger
Cab Glass	Windshield, tinted laminated glass - 1900 in. <sup>2</sup>
Center Console	Standard
Door Locks	Driver & passenger, electric control
Driver's Seat	Fore/aft and seat back angle adjustable cloth cover with headrest
Passenger Seat	Fixed with headrest
Center Seat	Folding with center console
Seat Belts	Driver & passenger, 3-point ELR type, center seat w/2-point lap belt
Rearview Mirrors	West coast type
Steering Column	Tilt & telescopic type
Sun Visors	Driver & passenger
Windows	Driver & passenger, electric control
Windshield Wipers	Dual, electric-driven, intermittent & 2 speed

## ELECTRICAL

Halogen headlights, 2 lamps  
Back-up lights (2)  
Cigar lighter  
Clearance, identification & side  
marker lights  
Day-time running lights  
Interior light  
License light  
Side turn signal lights  
Stop/tail lights  
Turn signal/hazard lights

## INSTRUMENTS

### Meters & Gauges

Coolant temperature gauge  
Fuel gauge  
Speedometer, odometer & trip meter  
Tachometer

### Warning & Indicator Lights & Buzzer

ABS warning light  
Air heater indicator light  
Alternator low charge warning light  
Brake low vacuum warning light  
Engine control system warning light  
Exhaust brake indicator light  
Hazard warning flasher  
High beam indicator light  
Low oil pressure warning light  
Low brake fluid level warning light  
Low coolant level light & buzzer  
Parking brake indicator light  
Sedimentor warning light  
Turn signal indicator lights  
Warning lights with burn-out bulb  
check function  
Automatic transmission:  
- Electric system warning light  
- High temperature fluid warning light  
- Overdrive cancel indicator light

## OTHER OPTIONS

Air conditioning  
AM/FM stereo radio with CD  
Block heater

## NOT AVAILABLE FOR SALE in California, Massachusetts and Maine

All illustrations, specifications and descriptions in this specification are based on the latest product information available at the time of this publication. The right is reserved to make changes in price, materials, equipment, design, specifications, diagrams and models, and to discontinue models of equipment at any time, without notice and without incurring any obligation whatsoever. For more information on additional options and accessories, contact NISSAN DIESEL AMERICA, INC.

Manufacturer:  
NISSAN DIESEL MOTOR CO., LTD.  
Tokyo, Japan

Distributor:  
NISSAN DIESEL AMERICA, INC.  
P.O. Box 152034  
Irving, Texas 75015-2034  
[www.nissandiesel.com](http://www.nissandiesel.com)